

Novasonar Ceiling 60 / Technical datasheet

Novasonar Ceiling 60 PN



PN version with integrated ML loudspeaker network even operatable with commercially available HiFi equipment.



Blends into the ceiling design ...

This flat-panel loudspeaker is suitable for the direct integration into ceiling grids. The loudspeaker consists of a commercial fiber board, reconstructed to a flat-panel loudspeaker.

Therefore Model Novasonar Ceiling can be delivered in nearly all **original surface designs** of commercial ceiling grids.

A & E Specifications

Description:

Flat-panel loudspeaker in modular ceiling format.

The loudspeaker system that works on the principle of a bending-wave transducer. It has a flat-panel membrane, which is set into vibration by an exciter that is mounted on the rear. This loudspeaker consists of a commercial fiber board reconstructed to a flat-panel diaphragm loudspeaker and matches the 60 cm x 60 cm modular ceiling format. The loudspeaker is already provided with the **original** surface design and material of the ceiling fiber board.

The frame has a particularly robust design to reduce the transfer of the membrane vibrations to the surrounding ceiling structure, which could cause the ceiling to rattle. There are no annoying and visible intermediate damping layers. A 100-V transformer and a passive crossover network is also available as an option.

Dimensions: 595 mm x 595 mm x 44 mm
equiv. to ceiling grid format
other sizes upon request

Frequency range: 100 Hz – 18000 Hz

Dispersion angle: 180° x 180°

Power handling: 60 W / 4 (16) ohms

Sensitivity: 85 dB (1 W / 1m)

Max. SPL: 103 dB (1 m)

Manufacturer: ML Audio+Carbons

Model: Novasonar Ceiling 60 (PN)

DIMENSIONS (HxWxD)	595 mm x 595 mm x 44 mm equiv. to ceiling grid format other sizes upon request
WEIGHT	4,5 kg
FREQUENCY RANGE	100 Hz – 18000 Hz
POWER HANDLING	60 watts RMS (HP 48 dB/oct 150 Hz)
SENSITIVITY	85 dB 1 watt / 1 metre
DISPERSION ANGLE HxV	180° x 180°
IMPEDANCE	4 (16) ohms
CONNECTION	standard cable
DESIGN	Original surface design on demand

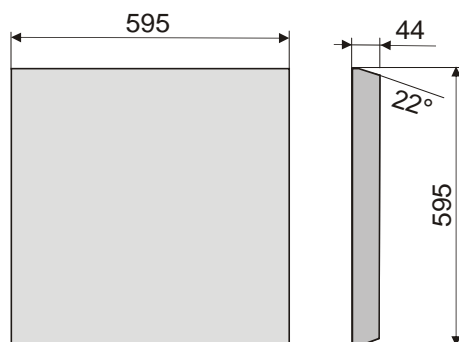

All products subject to technical modification without prior notice. Errors excepted

ML Audio + Carbons GmbH Lautsprechertechnik - Ulmenstraße 15 - D-65428 Rüsselsheim
Tel. +49-(0)700-93735565 or +49-(0)163-5306360 - Fax +49-(0)6131-6030796
E-Mail: info@mllaudio.de - Web: www.mllaudio.de